

**PARTS
CATALOGUE
CATALOGUE
DE PIECES DETACHEES**

3AMH'03(6L52)

2B6L5-300F1

YAMAHA
GENUINE
Parts & Accessories

2006/9/1

NEWS NO.	DATE	COMMENT
PE0-OM-060013	Aug.,22,2006	COR:FIG.9 PROPELLER PART NAME CORRECTION

FOREWORD

This Parts Catalogue is related to the parts for the model(s) in the below frame. When you are ordering replacement parts, please refer to this Parts Catalogue and quote both part numbers and part names correctly.

3AMH'03(6L52)

1. Modifications or additions which have been made after issue of the Parts Catalogue will be announced in the Yamaha Parts News.
It is advisable that you make necessary corrections to the Parts Catalogue according to the Yamaha Parts News.

2. Abbreviations

The Following abbreviations are used in this Parts Catalogue.

“UR” Use specified parts number.

“UN” Use as many as needed.

“AP” Alternate Parts

“LM” Local Made
(Parts need to be ordered locally)

“O/S” Over Size

3. Parts, which are to be supplied in an assembly, are listed with a dot(.) in front of the part name as shown below.

EXAMPLE

CARBURETOR ASSY

.JET, PILOT

.NOZZLE, MAIN

4. Number of component for assembly

The numeral appearing to the right of each component part indicates the quantity of parts for each assembly unit.

EXAMPLE

PART NO.	DESCRIPTION	u	u	u	REMARKS
6E0-85500-70	C.D.I. MAGNETO ASSY	1			
6E0-85550-70	.ROTOR ASSY	1			
6E0-15723-00-94	.PULLY, STARTER	1			

5. Quantity Column Information

NAME for Q'TY COLUMN	APPLICABLE MODEL
3A	3AMH

6. Applicable Starting Serial No. and Color Code

1) Engine Starting Serial No.

3AMH S/L	6L5K : 1000001
----------	----------------

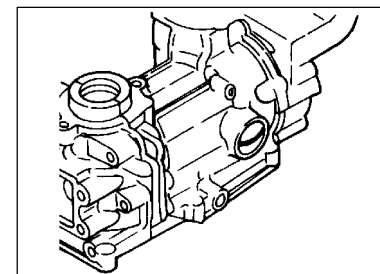
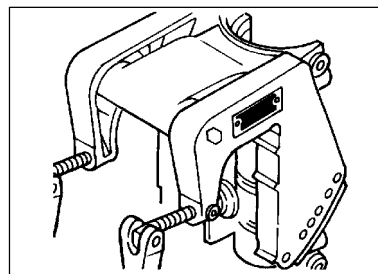

2) Color Code

Color Code	Color Name	Abbreviation
004D	DARK BLUISH GRAY METALLIC 2	DBNM2

7. Note that the illustrations for reference in finding parts numbers, not to be used for assembling. When assembling, please use the applicable service manual.
8. The asterisk (*) before a reference number indicates modification items after the first edition.

CONTENTS

COWLING . FUEL	A4
CYLINDER. CRANKCASE	A6
INTAKE	B1
STARTER	B3
GENERATOR	B4
ELECTRICAL	B5
CONTROL	B6
UPPER CASING . BRACKET	C1
LOWER CASING. DRIVE	C4
REPAIR KIT	C7

INDEX

NUMERICAL INDEX	D2
-----------------------	----

FIG. 1 COWLING . FUEL

CAPOT, SECTION D'ALIMENTATION

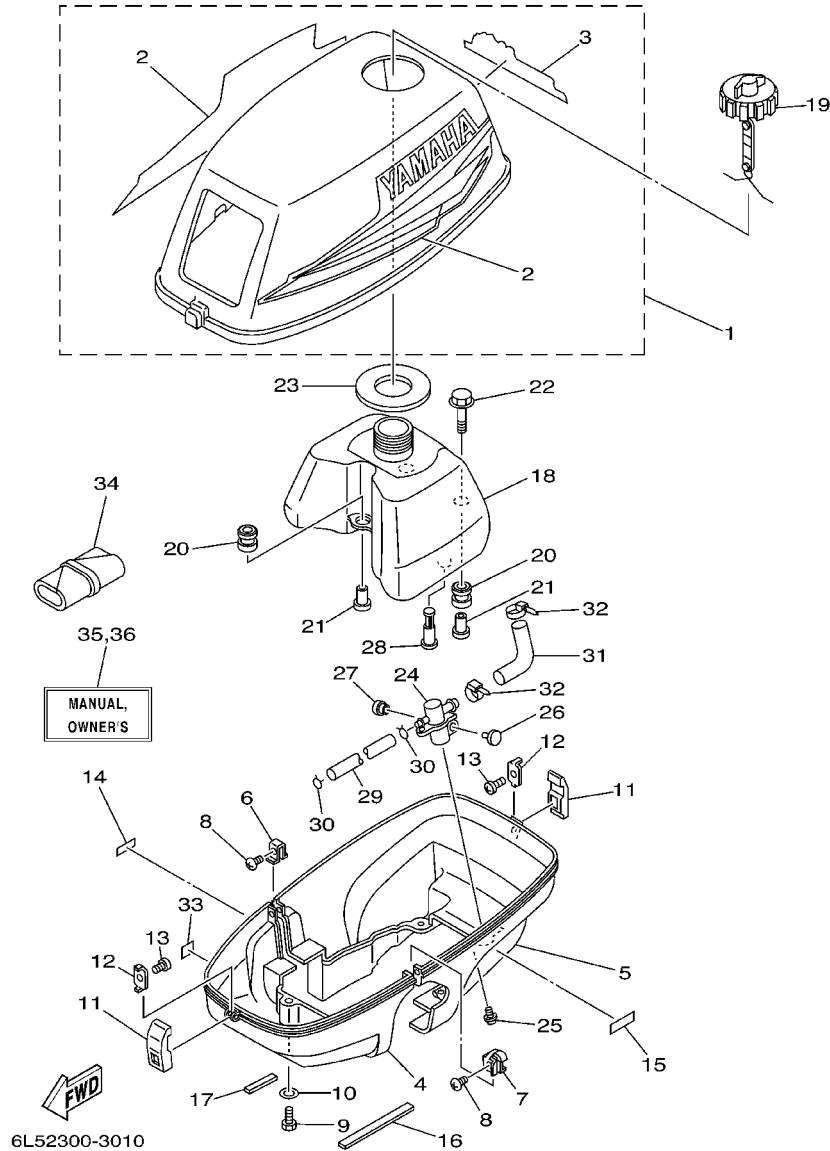

REF. NO.	PART NO. NO. PIECES	DESCRIPTION DESCRIPTION	3A				REMARKS REMARQUES
1	6L5-42610-54-4D	TOP COWLING ASSY CAPOT (ENS.)	1				
2	6L5-W0070-13	.GRAPHIC SET .JEU DIEMBLEMES	1				
3	6L5-42678-51	.GRAPHIC, REAR .ADHESIF, ARRIERE	1				
4	6L5-42711-11	COWLING, BOTTOM CUVETTE	1				
5	6L5-42712-12	COWLING, BOTTOM CUVETTE	1				
6	6L5-42774-00	STAY, APRON 1 COUSSINET	1				
7	6L5-42775-00	STAY, APRON 2 COUSSINET	1				
8	97880-05010	SCREW, PAN HEAD VIS, TETE TRONCONIQUE	2				
9	97095-06016	BOLT BOULON	4				
10	92995-06600	WASHER RONDELLE	4				
11	6L5-42647-00	HOLDER, CLAMP BAND SUPPORT, SANDOW DE SERRAGE	2				
12	6L5-42823-00	PLATE, STOP PLAQUE	2				
13	90167-03M02	SCREW, TAPPING VIS, TETE FRAISEE	2				
14	6L5-44191-00	INDICATOR, SHIFT ETIQUETTE, EMBRAYAGE	1				
15	6L5-24591-00	EMBLEM, FUEL COCK ADHESIF	1				
16	6L5-42662-00	DAMPER AMORTISSEUR	1				
17	6L5-42663-00	DAMPER AMORTISSEUR	1				
18	6L5-24111-02	TANK, FUEL RESERVOIR, A ESSENCE	1				
19	6L5-24610-20	CAP ASSY BOUCHON	1				
20	6A0-82317-00	DAMPER, IGNITION COIL AMORTISSEUR, BOBINE D'ALLUM	3				
21	624-42542-00	PIPE TUYAU	3				
22	90119-06M65	BOLT, WITH WASHER BOULON, AVEC RONDELLE	2				
23	6L5-24641-00	GASKET, CAP 1 JOINT 1, BOUCHON	1				
24	6L5-24500-60	FUEL COCK ASSY 1 ROBINET A ESSENCE	1				
25	90159-06M10	SCREW, WITH WASHER VIS, AVEC RONDELLE	1				
26	6L5-44196-20	INDICATOR 3 INDICATEUR 3	1				
27	6L5-44197-20	INDICATOR 4 INDICATEUR 4	1				

**CRANK CYLINDER
ASSY**
(Fig. 2, Ref. No. 2 to 42)

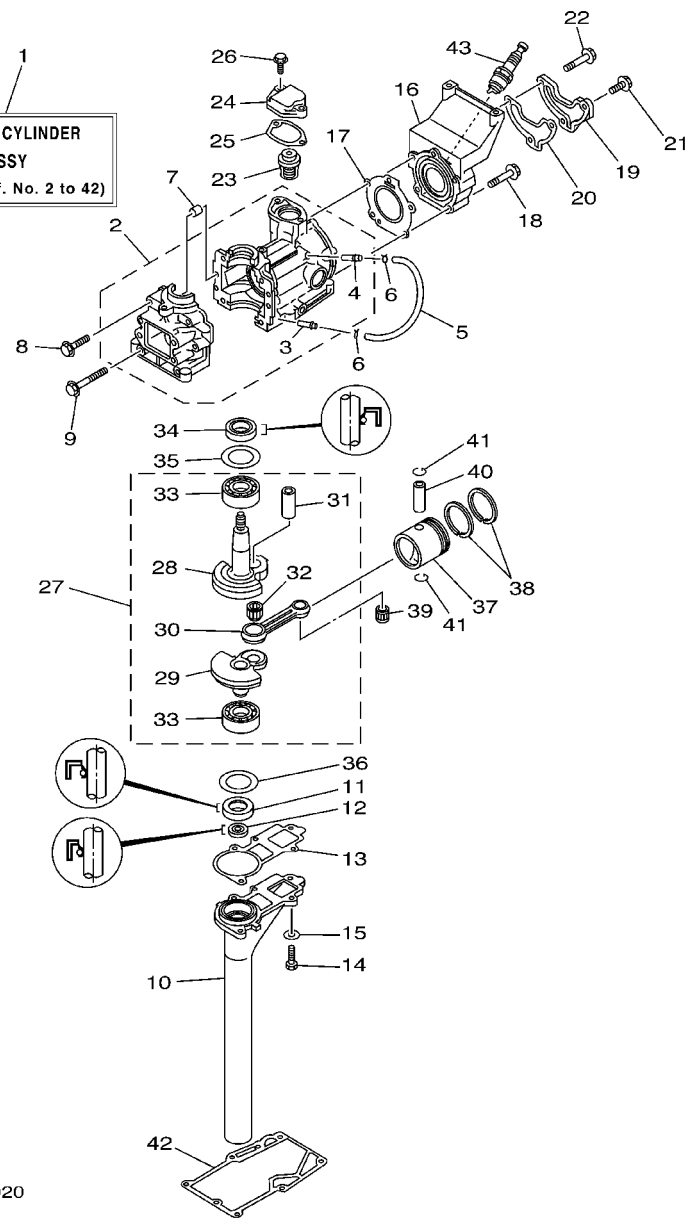
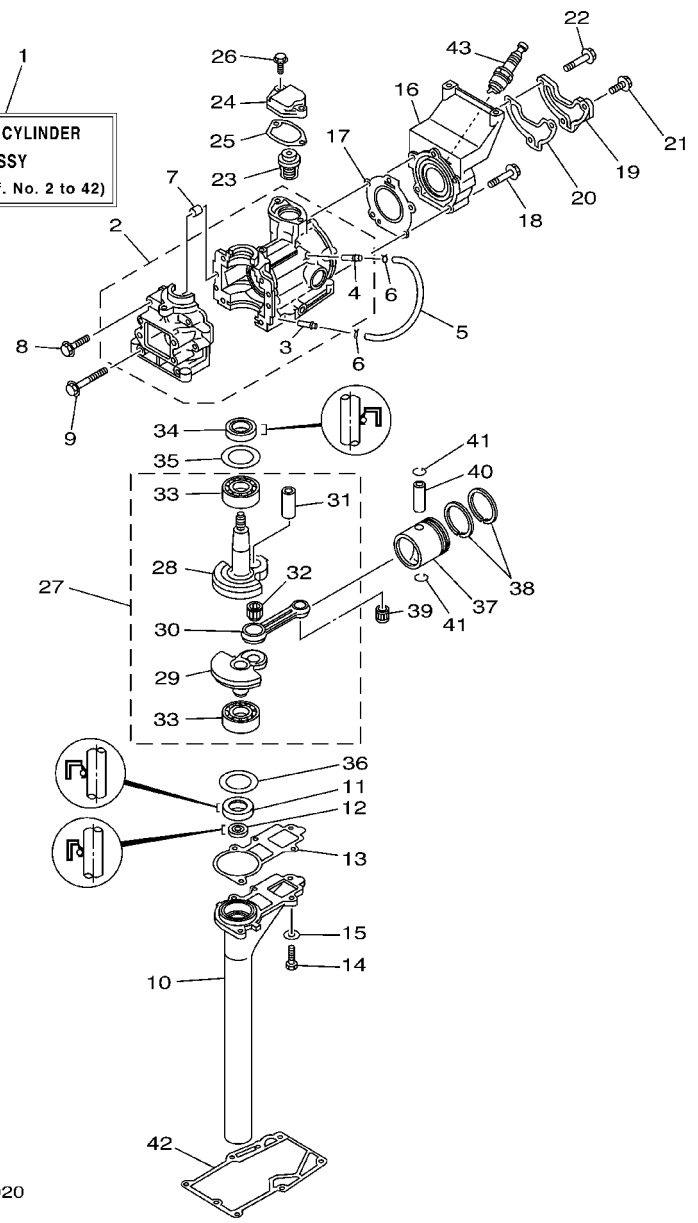

FIG. 2 CYLINDER. CRANKCASE CYLINDRE. CARTER

REF. NO.	PART NO. NO. PIECES	DESCRIPTION DESCRIPTION	3A				REMARKS REMARQUES
1	6L5-W0090-01-1S	CRANK CYLINDER ASSY EMBIELLAGE CYLINDRE (ENS.)	1				
2	6L5-15100-00-1S	CRANKCASE ASSY CARTER DE MOTEUR COMPLET	1				
3	624-14485-00	.PIPE, JOINT .DURITE	1				
4	6E5-11372-01	.NIPPLE, HOSE .RACCORD, TUYAU	1				
5	90445-07M29	HOSE (L135) DURITE (L135)	1				
6	90467-06016	CLIP JONC	2				
7	93606-12019	PIN, DOWEL GOUPILLE	2				
8	90105-06M16	BOLT, FLANGE BOULON	4				
9	90105-06M40	BOLT, FLANGE BOULON	2				
10	6L5-15396-00-94	HOUSING, OIL SEAL LOGEMENT DE JOINT SPY	1				
11	93101-20M29	OIL SEAL JOINT SPY	1				
12	93101-09M42	OIL SEAL JOINT SPY	1				
13	6L5-15369-A0	GASKET, OIL SEAL HOUSING JOINT SPY DE LOGEMENT	1				
14	97095-06020	BOLT BOULON	5				
15	92995-06600	WASHER RONDELLE	5				
16	6L5-11111-00-1S	HEAD, CYLINDER 1 CULASSE	1				
17	6L5-11181-A2	GASKET, CYLINDER HEAD 1 JOINT, DE CULASSE 1	1				
18	90119-06047	BOLT, WITH WASHER BOULON, AVEC RONDELLE	3				
19	6L5-11191-00-1S	COVER, CYLINDER HEAD 1 COUVERCLE, CULASSE 1	1				
20	6L5-11193-A1	GASKET, HEAD COVER 1 JOINT, COUVERCLE DE CULASSE 1	1				
21	90119-06MA2	BOLT, WITH WASHER BOULON, AVEC RONDELLE	1				
22	90119-06027	BOLT, WITH WASHER BOULON, AVEC RONDELLE	2				
23	6E5-12411-01	THERMOSTAT THERMOSTAT	1				
24	6L5-12413-00-1S	COVER, THERMOSTAT COUVERCLE, THERMOSTAT	1				
25	6L5-12414-A1	GASKET, COVER JOINT, COUVERCLE	1				
26	90119-06MA2	BOLT, WITH WASHER BOULON, AVEC RONDELLE	2				
27	6L5-11400-00	CRANKSHAFT ASSY VILEBREQUIN COMPLET	1				

**CRANK CYLINDER
ASSY**
(Fig. 2, Ref. No. 2 to 42)



6L52100-3020

FIG. 2 CYLINDER. CRANKCASE CYLINDRE. CARTER

REF. NO.	PART NO. NO. PIECES	DESCRIPTION DESCRIPTION	3A				REMARKS REMARQUES
28	6L5-11412-00	.CRANK 1 .MASSOLOTTE DE VILEBREQUIN 1	1				
29	6L5-11422-00	.CRANK 2 .MASSOLOTTE DE VILEBREQUIN 2	1				
30	6L5-11651-00	.ROD, CONNECTING BIELLE NUE	1				
31	6L5-11681-00	.PIN, CRANK 1 .MANETON, VILEBREQUIN 1	1				
32	93310-416N7	.BEARING .ROULEMENT	1				
33	93306-204U0	.BEARING .ROULEMENT	2				
34	93102-20M06	OIL SEAL JOINT SPY	1				
35	90201-32M00	WASHER, PLATE RONDELLE, PLATE	1				
36	90201-32M01	WASHER, PLATE RONDELLE, PLATE	1				
37	6L5-11631-00-96	PISTON (STD) PISTON (STD)	1				
	6L5-11635-00	PISTON (0.25MM O/S) PISTON (0.25MM O/S)	1				AP
	6L5-11636-00	PISTON (0.50MM O/S) PISTON (0.50MM O/S)	1				AP
38	6L5-11610-00	PISTON RING SET (STD) JEU DE SEGMENTS (STD)	1				
	6L5-11610-10	PISTON RING SET (0.25MM O/S) JEU DE SEGMENTS (0.25MM O/S)	1				AP
	6L5-11610-20	PISTON RING SET (0.50MM O/S) JEU DE SEGMENTS (0.50MM O/S)	1				AP
39	93310-112U0	BEARING ROULEMENT	1				
40	6L5-11633-00	PIN, PISTON AXE, PISTON	1				
41	93450-13022	CIRCLIP CIRCLIP	2				
42	6L5-45113-A1	GASKET, UPPER CASING JOINT, TUBE D'ARBRE	1				
43	94702-00274	PLUG SPARK (NGK BR6HS-10) BOUGIE D'ALLUMAGE (NGK BR6HS-10)	1				

FIG. 3 INTAKE

ADMISSION

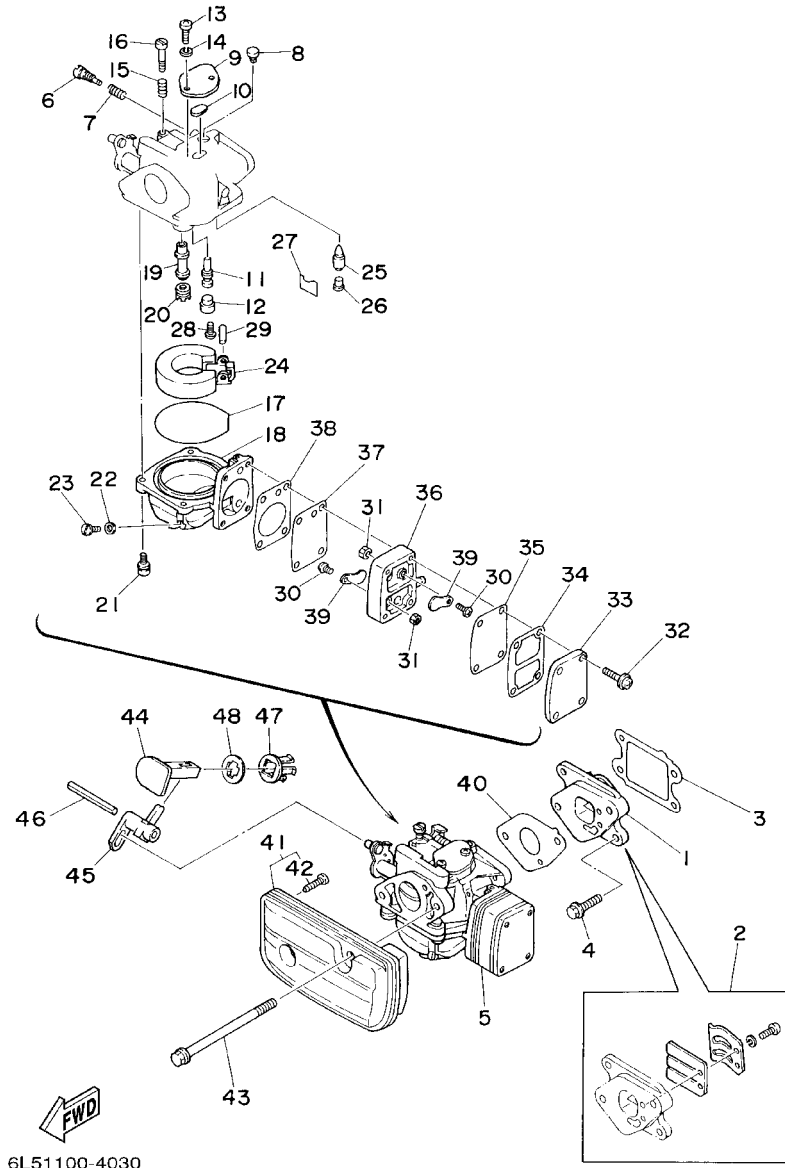

6L51100-4030

REF. NO.	PART NO. NO. PIECES	DESCRIPTION DESCRIPTION	3A				REMARKS REMARQUES
1	6L5-13610-02	REED VALVE ASSY CLAPET COMPLET	1				
2	6L5-W0004-02	.REED SET .JEU DE CLAPETS	1				
3	6L5-13621-A2	GASKET, VALVE SEAT JOINT, SIEGE DE CLAPET	1				
4	95895-06016	BOLT, FLANGE BOULON	2				
5	6L5-14301-03	CARBURETOR ASSY 1 CARBURATEUR COMPLET 1	1				
6	679-14923-00	.SCREW, PILOT .VIS, RALENTI	1				
7	679-14555-00	.SPRING .RESSORT	1				
8	6G1-14966-00	.CAP .CAPUCHON	1				
9	6G1-14527-00	.PLATE .PLAQUE	1				
10	6G1-14126-00	.GASKET JOINT	1				
11	6L5-14948-03	.JET (#40) .GICLUR (#40)	1				
12	676-14966-00	.CAP .CAPUCHON	1				
13	97880-04010	.SCREW, PAN HEAD .VIS, TETE TRONCONIQUE	2				
14	92990-04100	.WASHER, SPRING .RONDELLE, GROWER	2				
15	90501-10326	.SPRING, COMPRESSION .RESSORT, COMPRESSION	1				
16	63V-14523-00	.SCREW, STOP .VIS, BUTEE	1				
17	6G1-14984-00	.O-RING JOINT TORIQUE	1				
18	6G1-14980-01	.BODY, FLOAT CHAMBER .CORPS, CUVE DE FLOTTEUR	1				
19	6L5-14947-01	.JET, NEEDLE GICLUR DE STARTER	1				
20	676-14943-14	.JET, MAIN (#68) GICLUR, PRINCIPAL (#68)	1				
21	97980-04114	.SCREW, WITH WASHER .VIS, AVEC RONDELLE	4				
22	6G1-14398-00	.WASHER .RONDELLE	1				
23	6G1-14992-00	.SCREW, DRAIN BOUCHON, PURGE	1				
24	6G1-14985-00	.FLOAT FLOTTEUR	1				
25	6G1-14546-00	.VALVE, NEEDLE .POINTEAU	1				
26	676-14186-00	.PIN, FLOAT .AXE, FLOTTEUR	1				
27	663-14159-00	.CLIP .JONC	1				

FIG. 3 INTAKE

ADMISSION

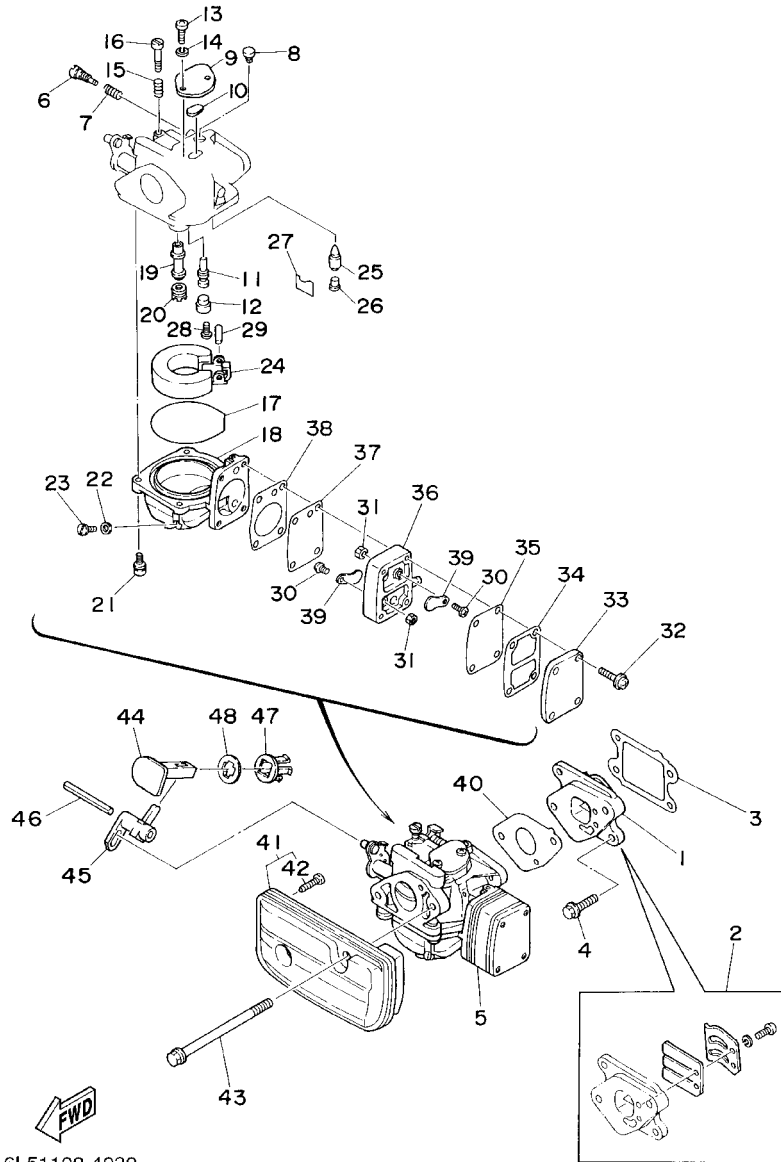

6L51100-4030

REF. NO.	PART NO. NO. PIECES	DESCRIPTION DESCRIPTION	3A				REMARKS REMARQUES
28	98580-04008	.SCREW, PAN HEAD .VIS	1				
29	688-14548-00	.PIN, FLOAT ARM .AXE, BRAS DE FLOTTEUR	1				
30	98580-03006	.SCREW, PAN HEAD .VIS	2				
31	95380-03600	.NUT .ECROU	2				
32	97980-04125	.SCREW, WITH WASHER .VIS, AVEC RONDELLE	4				
33	6G1-24452-00	.COVER .COUVERCLE	1				
34	6G1-24432-00	.GASKET, FUEL PUMP 2 .JOINT 2 DE POMPE A ESSENCE	1				
35	6G1-24471-00	.DIAPHRAGM .DIAPHRAGME	1				
36	6G1-24412-01	.BODY 1 .CORPS 1	1				
37	6G1-24411-00	.DIAPHRAGM .DIAPHRAGME	1				
38	6G1-24431-01	.GASKET, FUEL PUMP 1 .JOINT 1 DE POMPE A ESSENCE	1				
39	6L5-24421-00	.VALVE, CHECK .SOUPAPE, RETENUE	2				
40	6L5-14198-A1	GASKET JOINT	1				
41	6L5-14440-00	SILENCER ASSY, INTAKE SIENCIEUX D'ADMISSION	1				
42	97780-40716	.SCREW, TAPPING .VIS, TETE BOMBEE	2				
43	95895-06095	BOLT, FLANGE BOULON	2				
44	6L5-41271-20	KNOB, CHOKE BOUTON DE STARTER	1				
45	6L5-41252-00	LEVER, CHOKE 1 LEVIER 1	1				
46	91690-40048	PIN, SPRING AGRAFFE	1				
47	689-41273-00	GROMMET PASSE-FIL	1				
48	6J8-41274-00	GROMMET 2 PASSE-FIL 2	1				

FIG. 4 STARTER

DEMARREUR

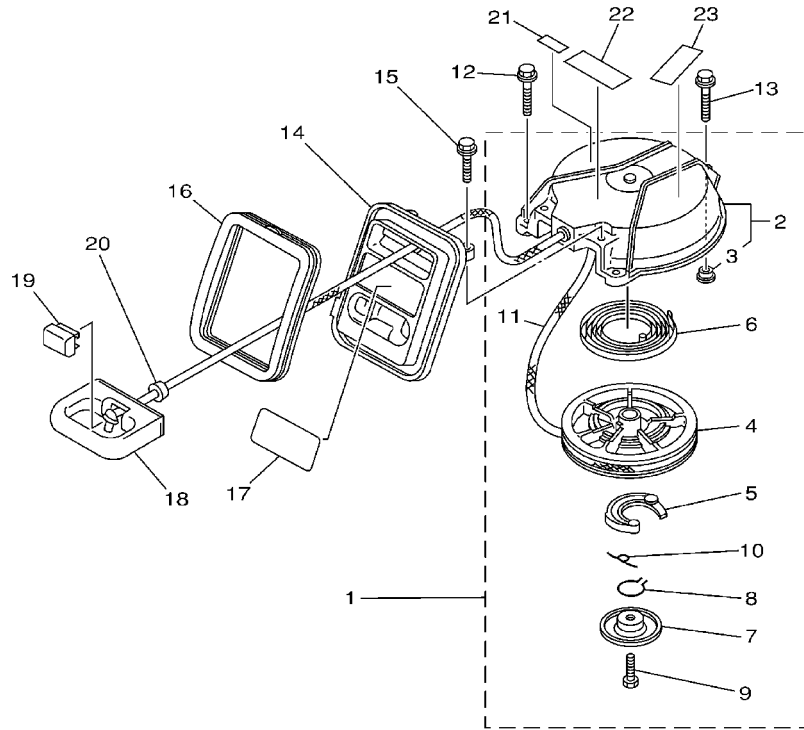

REF. NO.	PART NO. NO. PIECES	DESCRIPTION DESCRIPTION	3A				REMARKS REMARQUES
1	6L5-15710-00	STARTER ASSY DEMARREUR COMPLET	1				
2	6L5-15711-00	.CASE, STARTER .CARTER DE DEMARREUR	1				
3	90387-06M70	..COLLAR ..COLLERETTE	1				
4	6L5-15714-00	.DRUM, SHEAVE .TAMBOUR, POULIE	1				
5	6L5-15741-00	.PAWL, DRIVE ..CLIQUET, ENTRAINEMENT	1				
6	6L5-15713-00	.SPRING, STARTER ..RESSORT DE DEMARREUR	1				
7	6L5-15716-00	.PLATE, DRIVE ..PLAQUE, ENTRAINEMENT	1				
8	6A1-15705-00	.SPRING, DRIVE PAWL ..RESSORT DE CLIQUET	1				
9	97313-06012	.BOLT ..BOULON	1				
10	6A1-15767-00	.SPRING ..RESSORT	1				
11	*	.WIRE (L:1650MM) .FIL (L:1650MM)	1				
12	95895-06020	BOLT, FLANGE BOULON	2				
13	95895-06035	BOLT, FLANGE BOULON	1				
14	6L5-15758-00-98	GUIDE, ROPE GUIDE DE CABLE	1				
15	95895-06016	BOLT, FLANGE BOULON	2				
16	6L5-15761-00	SEAL, RUBBER 1 JOINT CAOUTCHOUC 1	1				
17	6L5-42677-10	GRAPHIC, FRONT ADHESIF, AVANT	1				
18	6L5-15755-00	HANDLE, STARTER POIGNEE, DE DEMARREUR	1				
19	6L5-15779-20	COVER COUVERCLE	1				
20	6L5-15789-00	DAMPER AMORTISSEUR	1				
21	6H8-42791-10	MARK 1 ETIQUETTE 1	1				
22	6A1-83625-41	MARK 5 ETIQUETTE 5	1				
23	6A1-83625-51	MARK 5 ETIQUETTE 5	1				

* CUT FROM 50M ROLLS, PART NO. 90790-77002,
CUTTING LENGTH 1.65M

* A PRELEVER SUR BOBINE 50M , REFERENCE 90790-77002,
LONGUEUR DE COUPE 1.65M



6L51100-2040

B3

FIG. 5 GENERATOR

GENERATRICE

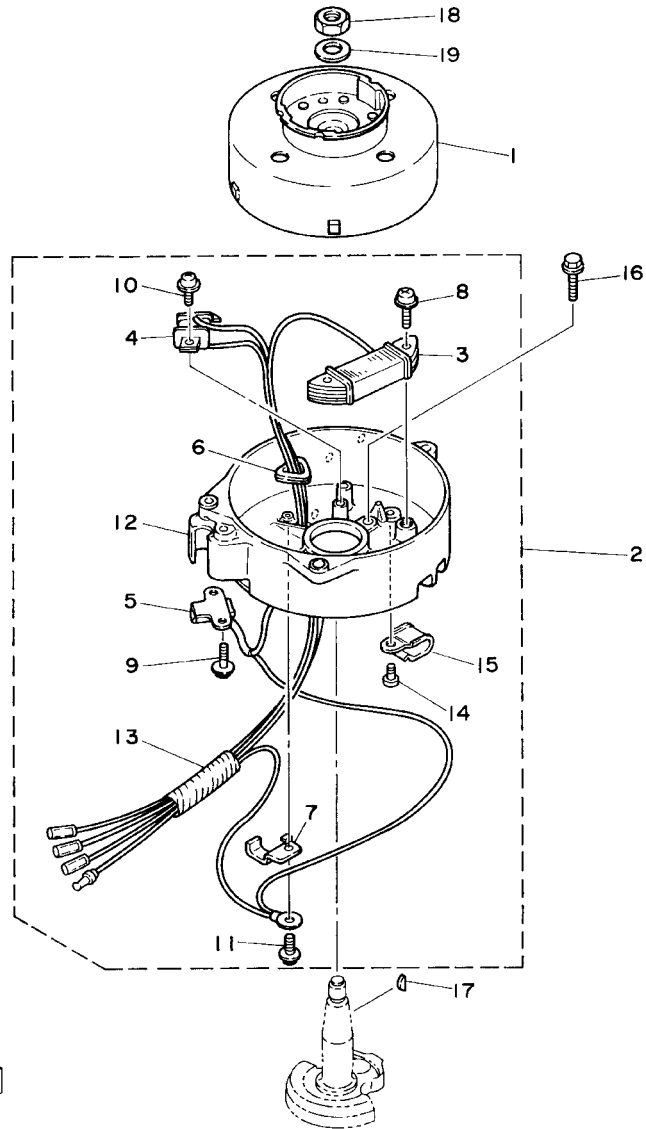

REF. NO.	PART NO. NO. PIECES	DESCRIPTION DESCRIPTION	3A				REMARKS REMARQUES
1	6L5-85550-M0	ROTOR ASSY ROTOR CPLT	1				
2	6L5-85560-M1	BASE ASSY ENS. FLASQUE	1				
3	6E0-85520-70	.COIL, CHARGE .BOBINE, CHARGE	1				
4	6L5-85595-M0	.COIL, PULSER .BOBINE, PULSEUR	1				
5	6L5-85592-M0	.PULSER COIL ASSY .PULSATION BOBINE (ENS.)	1				
6	6E0-81336-70	.GROMMET .OUILLET CAOUTCHOUC	1				
7	6E0-81328-70	.CLAMP .COLLIER	1				
8	90159-05038	.SCREW, WITH WASHER .VIS, AVEC RONDELLE	2				
9	90159-05037	.SCREW, WITH WASHER .VIS, AVEC RONDELLE	2				
10	90159-04036	.SCREW, WITH WASHER .VIS, AVEC RONDELLE	2				
11	90159-04035	.SCREW, WITH WASHER .VIS, AVEC RONDELLE	1				
12	6L5-15771-01-94	.STAY 1 .SUPPORT 1	1				
13	90446-10M01	.HOSE .DURITE	1				
14	97803-05008	.SCREW, PAN HEAD .VIS, CRUCIFORME	1				
15	90465-10M34	.CLAMP .BRIDE	1				
16	95895-06016	.BOLT, FLANGE BOULON	2				
17	90280-04M06	KEY, WOODRUFF CLAVETTE, DEMI-LUNE	1				
18	90170-10113	NUT ECROU	1				
19	90201-10126	WASHER, PLATE RONDELLE, PLATE	1				



6L51100-4050

FIG. 6 ELECTRICAL

ELECTRIQUE

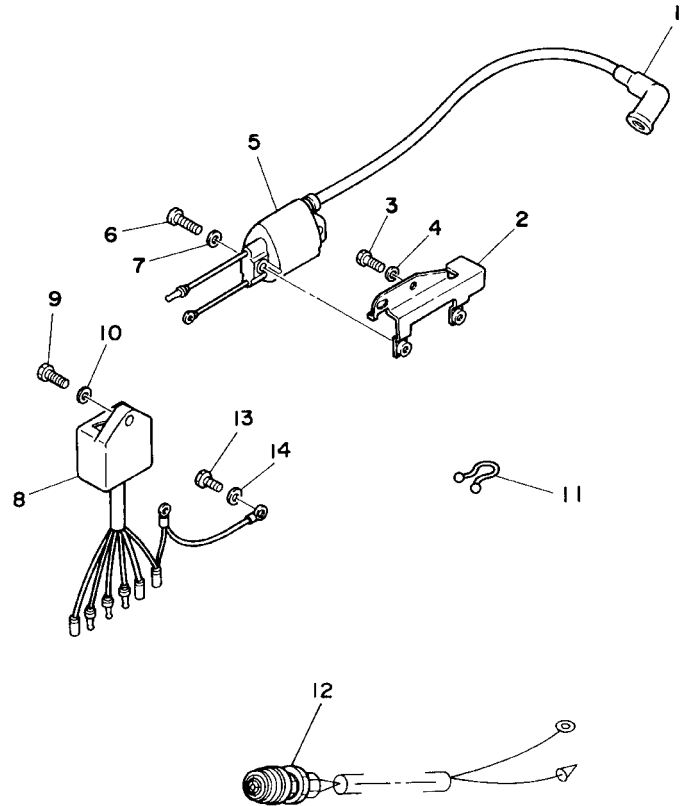

REF. NO.	PART NO. NO. PIECES	DESCRIPTION DESCRIPTION	3A				REMARKS REMARQUES
1	6G1-82370-21	PLUG CAP ASSY ANTIPARASITE	1				
2	6L5-82316-00	BRACKET, IGNITION COIL SUPPORT, BOBINE D'ALLUMAGE	1				
3	97095-06016	BOLT BOULON	2				
4	92995-06600	WASHER RONDELLE	2				
5	6L5-85570-N0	IGNITION COIL ASSY BOBINE D'ALLUMAGE (ENS.)	1				
6	97880-06016	SCREW, PAN HEAD VIS, TETE TRONCONIQUE	2				
7	92990-06600	WASHER, PLATE RONDELLE, PLATE	2				
8	6L5-85540-M0	C.D.I. UNIT ASSY BLOC C.D.I.	1				
9	97095-06016	BOLT BOULON	1				
10	92995-06600	WASHER RONDELLE	1				
11	90465-18147	CLAMP BRIDE	1				
12	6L5-82550-00	ENGINE STOP SWITCH ASSY COMMUTATEUR D'ARRET CPLT	1				
13	97090-06012	BOLT BOULON	1				
14	92990-06600	WASHER, PLATE RONDELLE, PLATE	1				



6L51100-4060

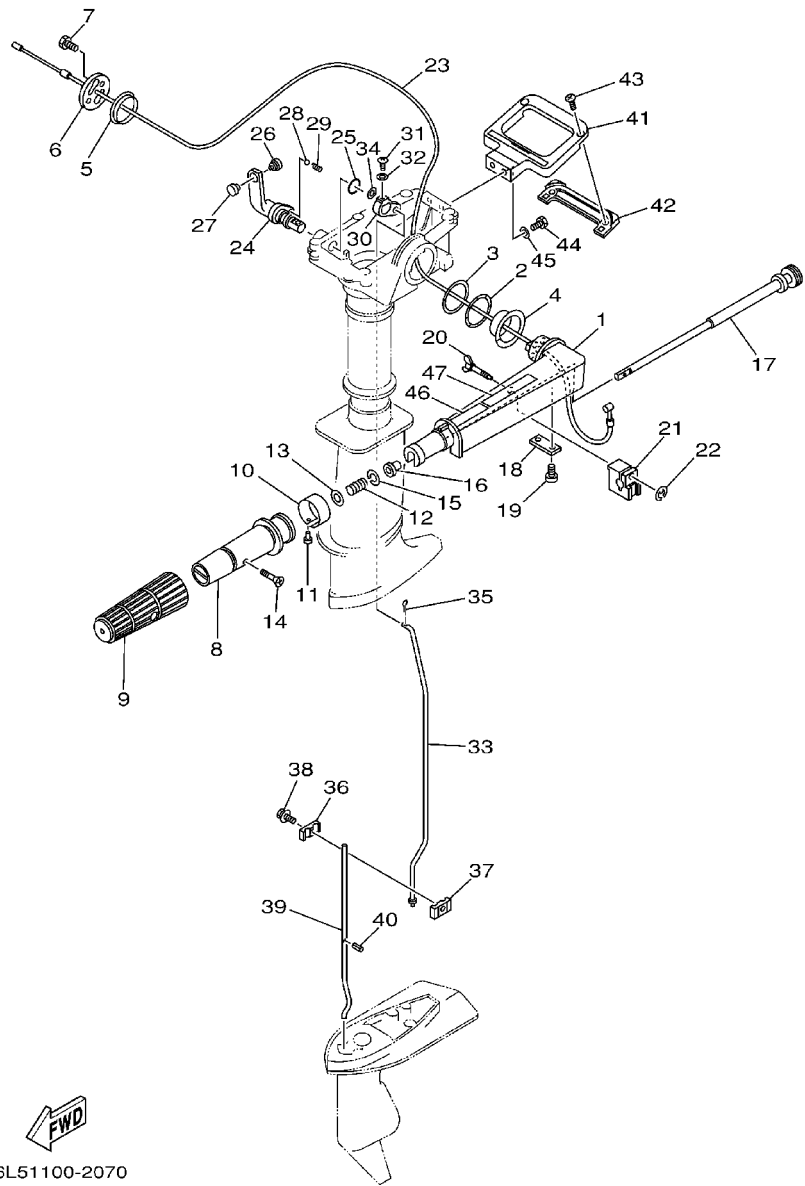

6L51100-2070

FIG. 7 CONTROL

COMMANDE

REF. NO.	PART NO. NO. PIECES	DESCRIPTION DESCRIPTION	3A				REMARKS REMARQUES
1	6G1-42111-11-4D	HANDLE, STEERING POIGNEE	1				
2	90206-36M21	WASHER, WAVE RONDELLE, ONDULEE	1				
3	90202-36M55	WASHER, PLATE RONDELLE, PLATE	1				
4	90386-34M97	BUSH DOUILLE	1				
5	90386-33M96	BUSH DOUILLE	1				
6	6G1-42131-01	COVER, HANDLE STEERING COUVERCLE	1				
7	97095-06020	BOLT BOULON	1				
8	664-42119-00	GRIP, STEERING HANDLE POIGNEE, BARRE FRANCHE	1				
9	6G1-42177-00	RUBBER, HANDLE CAOUTCHOUC, POIGNEE	1				
10	6L5-42137-20	INDICATOR, THROTTLE INDICATEUR, ACCELERATION	1				
11	90269-02M09	RIVET RIVET	1				
12	90501-23215	SPRING, COMPRESSION RESSORT, COMPRESSION	1				
13	92903-10600	WASHER, PLATE RONDELLE, PLATE	1				
14	90149-05M13	SCREW VIS	1				
15	90209-08M17	WASHER RONDELLE	1				
16	90386-08032	BUSH DOUILLE	1				
17	6G1-42138-01	LEVER, THROTTLE LEVIER, ACCELERATEUR	1				
18	6E0-42159-02	STAY SUPPORT	1				
19	97885-05012	SCREW, PAN HEAD VIS, A ENCOCHE	2				
20	6L5-42125-00	BOLT, FRICTION ADJUSTING BOULON	1				
21	6G1-42126-00	FRICTION, STEERING HANDLE GRIP CUVETTE, POIGNEE DE DIRECTION	1				
22	99080-03600	CIRCLIP CIRCLIP	1				
23	6L5-26301-01	THROTTLE CABLE ASSY CABLE D'ACCELERATEUR	1				
24	6L5-44111-00	HANDLE, GEAR SHIFT POIGNEE, LEVIER D'EMBRAYAGE	1				
25	93210-12327	O-RING JOINT TORIQUE	1				
26	6L5-44196-20	INDICATOR 3 INDICATEUR 3	1				
27	6L5-44197-20	INDICATOR 4 INDICATEUR 4	1				

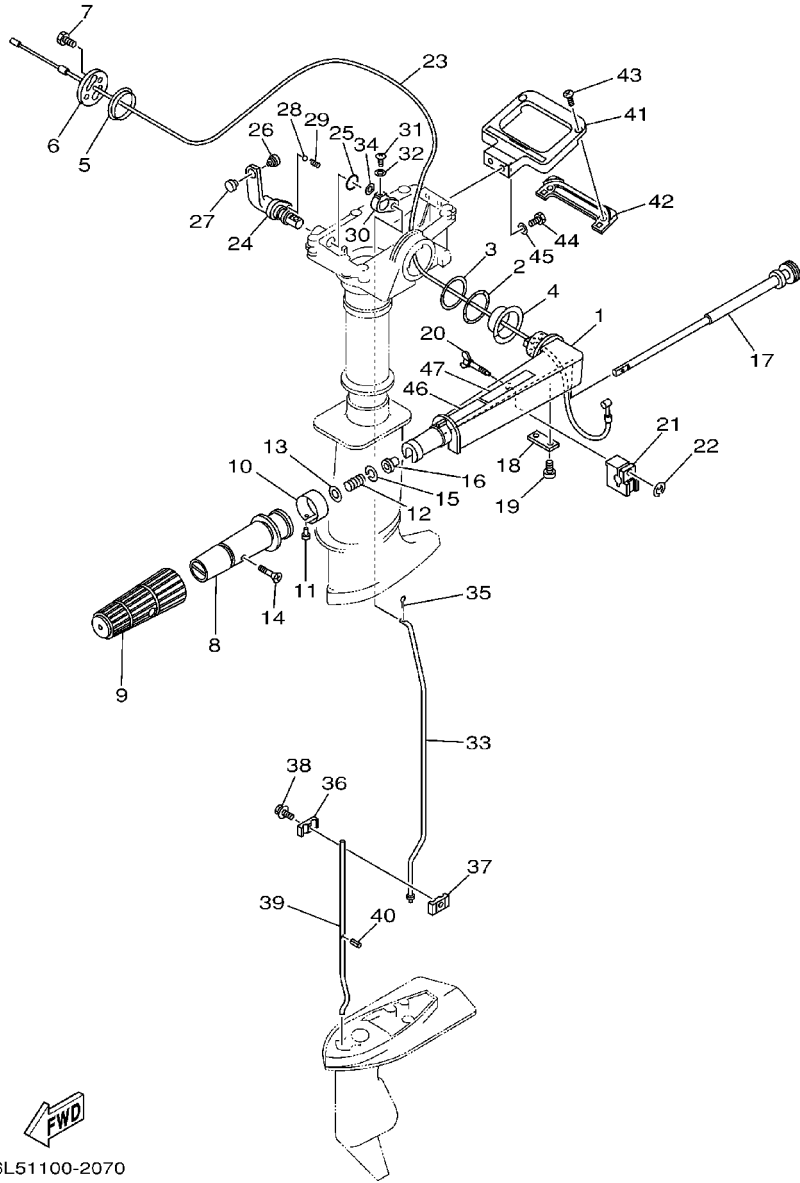

6L51100-2070

FIG. 7 CONTROL

COMMANDE

REF. NO.	PART NO. NO. PIECES	DESCRIPTION DESCRIPTION	3A				REMARKS REMARQUES
28	93505-16024	BALL BILLE ROULEMENT	1				
29	90501-12274	SPRING, COMPRESSION RESSORT, COMPRESSION	1				
30	6L5-44121-00	LEVER, SHIFT ROD LEVIER, TIGE D'INVERSION	1				
31	97780-40520	SCREW, TAPPING VIS, TETE BOMBEE	1				
32	92990-04600	WASHER, PLATE RONDELLE, PLATE	1				
33	6L5-44143-00	ROD, SHIFT TIGE D'EMBAYAGE	1				
34	92990-05600	WASHER, PLATE RONDELLE, PLATE	1				
35	91490-16010	PIN, COTTER GOUILLE	1				
36	6E0-44145-00	CONNECTOR, SHIFT ROD CONNECTEUR, TIGE D'INVERSION	1				
37	6E0-44146-00	CONNECTOR, SHIFT ROD CONNECTEUR, TIGE D'INVERSION	1				
38	95895-06020	BOLT, FLANGE BOULON	1				
39	6L5-44144-00	ROD, SHIFT TIGE D'EMBAYAGE	1				S
	6L5-44144-10	ROD, SHIFT TIGE D'EMBAYAGE	1				L
40	91609-25014	PIN, SPRING AXE DE RESSORT	1				
41	6L5-42731-00-4D	CARRYING HANDLE POIGNEE DE PORTAGE	1				
42	6L5-42735-20	PROTECTOR PROTECTEUR	1				
43	90161-04M02	SCREW, TAPPING VIS, TETE FRAISEE	2				
44	97095-06020	BOLT BOULON	2				
45	92995-06600	WASHER RONDELLE	2				
46	6A1-2415A-41	LABEL, CAUTION ETIQUETTE, RECOMMANDATION	1				
47	6A1-2415A-51	LABEL, CAUTION ETIQUETTE, RECOMMANDATION	1				

FIG. 8 UPPER CASING . BRACKET FOURREAU, SUPPORT

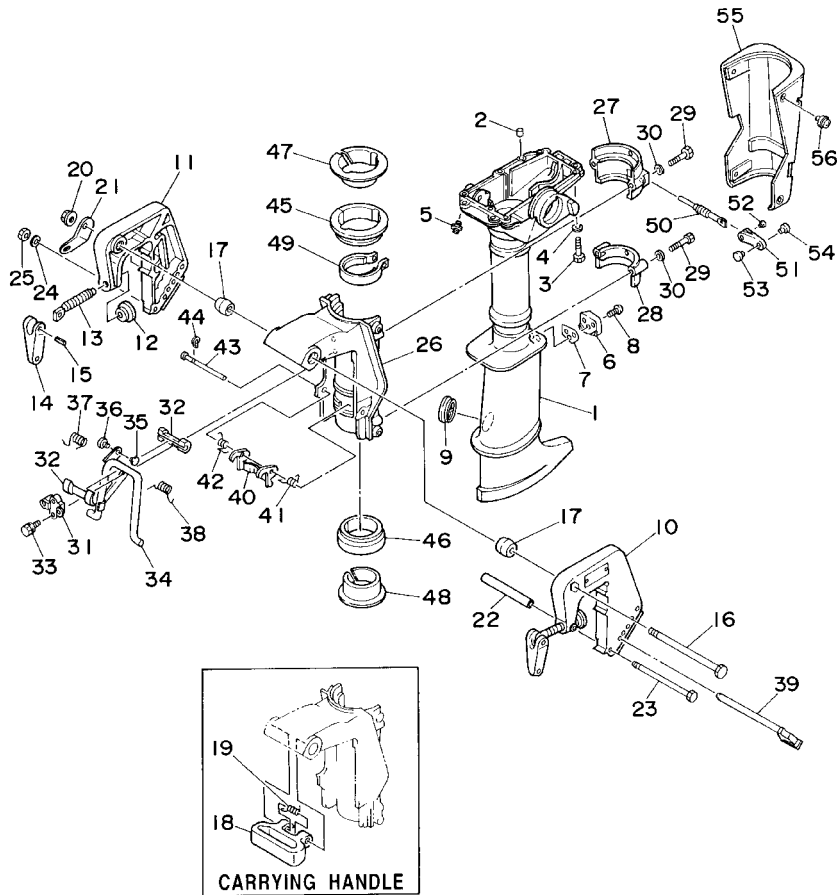



6L52110-3080

REF. NO.	PART NO. NO. PIECES	DESCRIPTION DESCRIPTION	3A				REMARKS REMARQUES
1	6L5-45111-02-4D	CASING, UPPER FOURREAU	1				
2	93604-12M07	PIN, DOWEL CLAVETTE	2				
3	97095-06030	BOLT BOULON	6				
4	92995-06600	WASHER RONDELLE	6				
5	93700-06M03	NIPPLE, GREASE PION	1				
6	6L5-45152-00	COVER, UPPER CASING 2 CAPUCHON FOURREAU	1				
7	6L5-45115-A0	GASKET, UPPER CASING JOINT, TUBE D'ARBRE	1				
8	90149-05M08	SCREW VIS	1				
9	647-45151-01	COVER, UPPER CASING CAPUCHON, FOURREAU	1				
10	6L5-43111-01-4D	BRACKET, CLAMP PRESSE	1				
11	6L5-43112-00-4D	BRACKET, CLAMP PRESSE	1				
12	620-43114-00	PAD, TRANSOM CLAMP RONDELLE D'APPUI	2				
13	6E0-43116-01	SCREW, TRANSOM CLAMP VIS DE PRESSE	2				
14	6E0-43118-01	HANDLE, TRANSOM CLAMP POIGNEE DE VIS DE PRESSE	2				
15	90243-04M01	PIN GOUPILLE	2				
16	90101-08M10	BOLT BOULON	1				
17	6G1-43136-00	PIECE, FRICTION FRICTION	2				
18	6L5-42121-00	BRACKET SUPPORT	1				
19	90508-16M30	SPRING, TORSION RESSORT, TORSION	1				
20	90185-08057	NUT, SELF-LOCKING ECROU, AUTO-BLOCANT	1				
21	6A1-43113-01	PLATE, CLAMP BRACKET PLAQUETTE, PRESSE	1				
22	90387-06M11	COLLAR COLLERETTE	1				
23	90101-06335	BOLT BOULON	1				
24	92990-06600	WASHER, PLATE RONDELLE, PLATE	1				
25	95380-06600	NUT, HEXAGON ECROU	1				
26	6L5-43311-01-4D	BRACKET, SWIVEL 1 SUPPORT, PIVOT 1	1				
27	6L5-44511-00-4D	COVER, UPPER MOUNT COUVERCLE, SUSPENSION SUPERIEUR	1				

C1

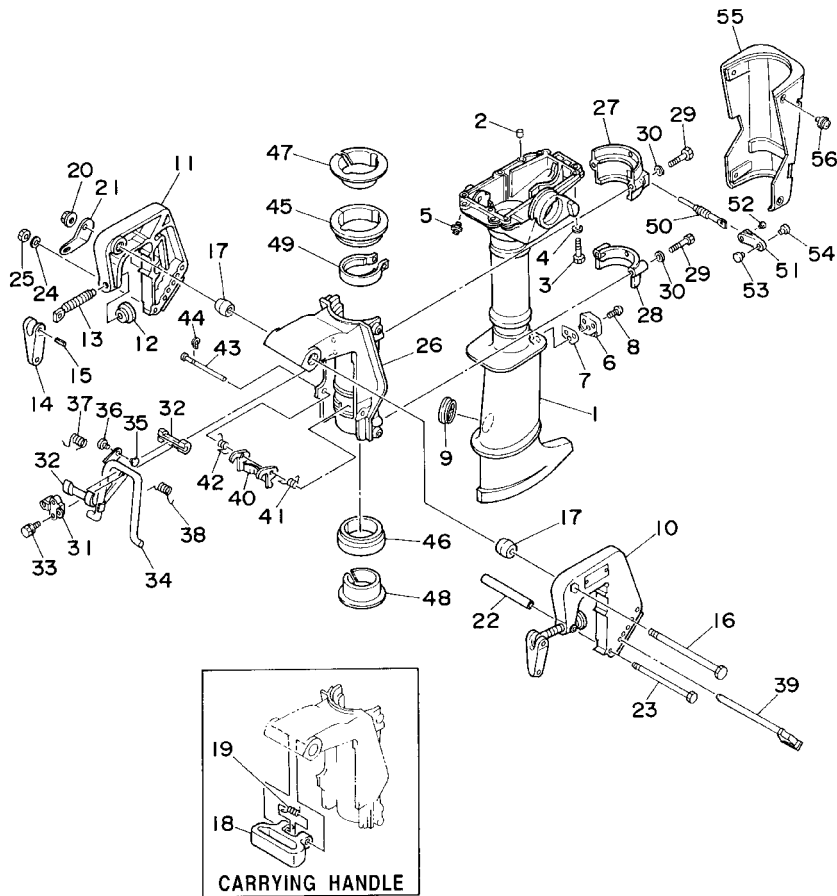
FIG. 8 UPPER CASING . BRACKET FOURREAU, SUPPORT



REF. NO.	PART NO. NO. PIECES	DESCRIPTION DESCRIPTION	3A				REMARKS REMARQUES
28	6L5-44553-00-4D	COVER, LOWER MOUNT COUVERCLE, SUSPENSION INFÉRIEURE	1				
29	97095-06035	BOLT BOULON	4				
30	92995-06600	WASHER RONDELLE	4				
31	6E0-43313-00-94	BRACKET, SWIVEL 3 SUPPORT, PIVOT 3	1				
32	620-43189-00	BUSHING COUSSINET	2				
33	95895-06020	BOLT, FLANGE BOULON	2				
34	6L5-43181-00	LEVER, TILT STOP LEVIER, VERROUILLAGE RELEVAGE	1				
35	6L5-44196-20	INDICATOR 3 INDICATEUR 3	1				
36	6L5-44197-20	INDICATOR 4 INDICATEUR 4	1				
37	90508-16020	SPRING, TORSION RESSORT, TORSION	1				
38	90508-16021	SPRING, TORSION RESSORT, TORSION	1				
39	6L5-43160-00	TILT ROD ASSY BROCHE D'INCLINAISON (ENS.)	1				
40	6L5-43614-00	PLATE, TILT LOCK ETRIER, VERROUILLAGE MARCHE AR	1				
41	90508-08M26	SPRING, TORSION RESSORT, TORSION	1				
42	90508-08M27	SPRING, TORSION RESSORT, TORSION	1				
43	6L5-43659-00	SHAFT, REVERSE LOCK AXE, VERROUILLAGE MARCHE AR	1				
44	99080-05600	CIRCLIP CIRCLIP	1				
45	6L5-42537-00	BUSHING, PIVOT SHAFT COUSSINET	1				
46	6L5-42538-00	BUSHING, PIVOT SHAFT COUSSINET	1				
47	6L5-42539-00	BUSHING, PIVOT SHAFT COUSSINET	1				
48	6L5-42549-00	BUSHING, PIVOT SHAFT COUSSINET	1				
49	6E0-42528-03	PLATE, FRICTION PLAQUE, FRICTION	1				
50	6L5-42529-01	SCREW, FRICTION PIECE VIS, PIECE DE FRICTION	1				
51	6L5-42561-00	KNOB, STEERING LOCK BOUTON	1				
52	90266-04M05	RIVET RIVET	1				
53	6L5-44196-20	INDICATOR 3 INDICATEUR 3	1				
54	6L5-44197-20	INDICATOR 4 INDICATEUR 4	1				

FWD
6L52110-3080

FIG. 9 LOWER CASING. DRIVE

BOITIER D'HELICE, TRANSMISSION

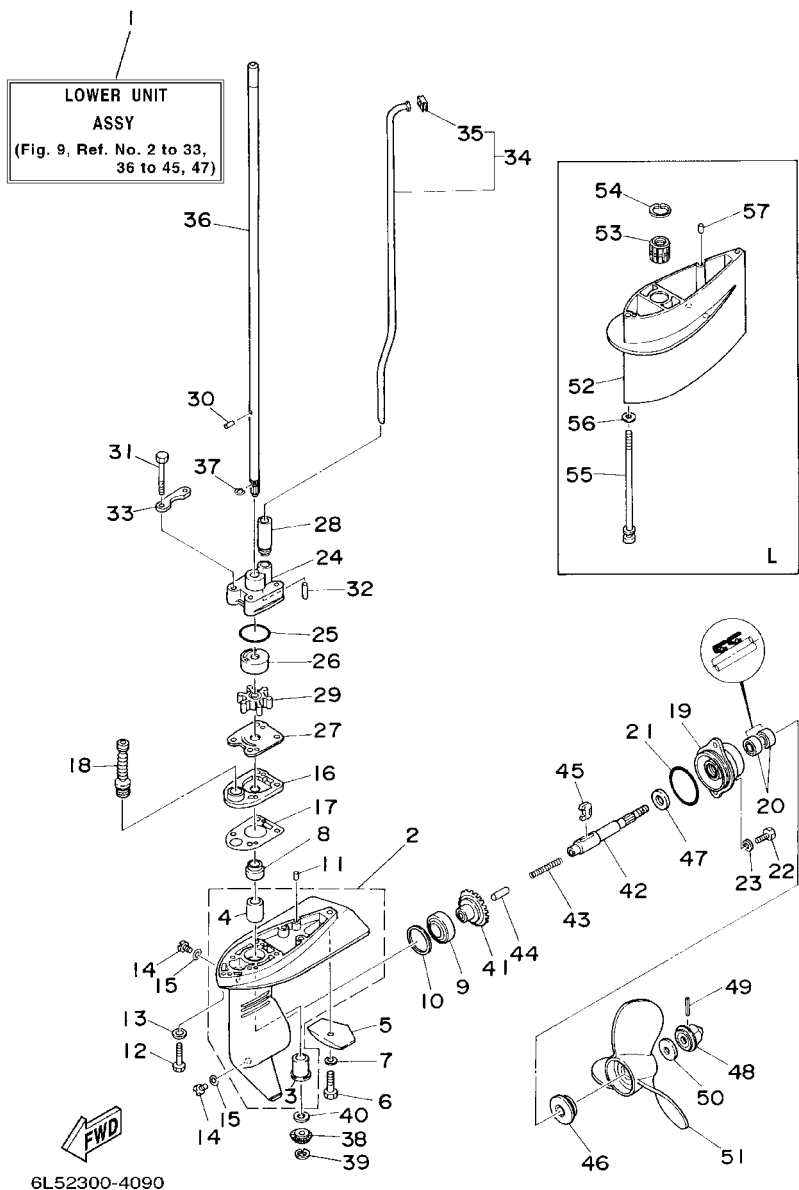

REF. NO.	PART NO. NO. PIECES	DESCRIPTION DESCRIPTION	3A				REMARKS REMARQUES
1	6L5-45300-01-4D	LOWER UNIT ASSY	1				S
	6L5-45300-11-4D	UNITE INFERIEURE (ENS.)	1				L
2	6L5-45311-00-4D	CASING, LOWER	1				
		BOITIER D'HELICE					
3	6L5-45317-09	.BUSHING, DRIVE SHAFT	1				
		.DOUILLE, ARBRE MOTEUR					
4	6L5-45316-09	.BUSHING, DRIVE SHAFT	1				
		.DOUILLE, ARBRE MOTEUR					
5	6L5-45251-03	ANODE	1				
		ANODE					
6	95895-06030	BOLT, FLANGE	1				S
		BOULON					
	90101-06M18	BOLT	1				L
		BOULON					
7	92990-06300	WASHER, INTERNAL TOOTH	1				
		RONDELLE, DENTURE INTERNE					
8	93103-09M41	OIL SEAL	1				
		JOINT SPY					
9	93316-003U0	BEARING	1				
		ROULEMENT					
10	6L5-45567-00	SHIM	1				UN
		CALE					
11	93604-12M07	PIN, DOWEL	2				
		CLAVETTE					
12	97095-06030	BOLT	3				
		BOULON					
13	92995-06600	WASHER	3				
		RONDELLE					
14	90340-08002	PLUG, STRAIGHT SCREW	2				
		PLOT, FILETE DROIT					
15	90430-08020	GASKET	2				
		JOINT					
16	6L5-45321-00-5B	PLATE	1				
		PLAQUETTE					
17	6L5-45315-A0	PACKING, LOWER CASING	1				
		JOINT, BOITIER D'HELICE					
18	6L2-44147-00	BOOT, SHIFT ROD	1				
		SOUFFLET, TIGE D'INVERSION					
19	6L5-45361-00-4D	CAP, LOWER CASING	1				
		COUVERCLE, BOITIER D'HELICE					
20	93101-13M12	OIL SEAL	2				
		JOINT SPY					
21	93210-48214	O-RING	1				
		JOINT TORIQUE					
22	97095-06016	BOLT	2				
		BOULON					
23	92995-06600	WASHER	2				
		RONDELLE					
24	6L5-44311-00	HOUSING, WATER PUMP	1				
		CORPS, POMPE A EAU					
25	93210-33M85	O-RING	1				
		JOINT TORIQUE					

FIG. 9 LOWER CASING. DRIVE

BOITIER D'HELICE, TRANSMISSION

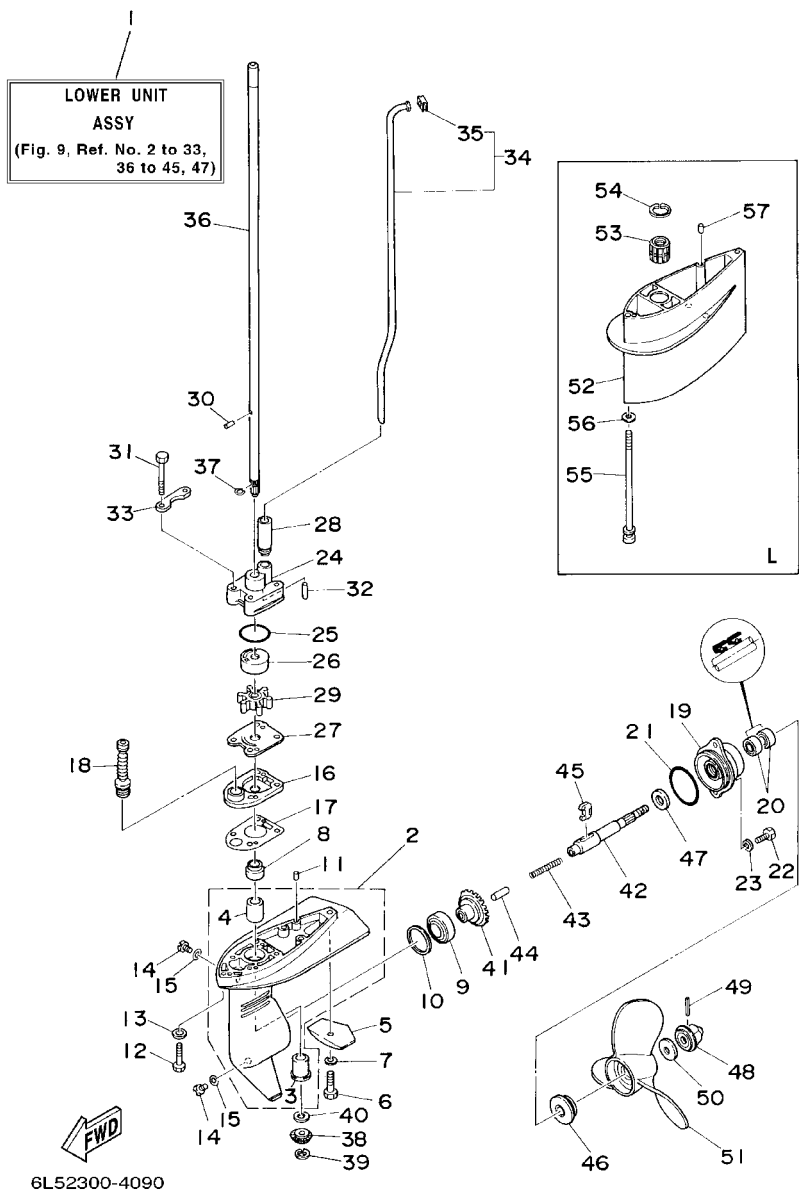

REF. NO.	PART NO. NO. PIECES	DESCRIPTION DESCRIPTION	3A				REMARKS REMARQUES
26	6L5-44322-00	INSERT, CARTRIDGE CUVETTE	1				
27	6L5-44323-00	OUTER PLATE, CARTRIDGE PLAQUE EXTERIEURE	1				
28	6E0-44366-00	DAMPER, WATER SEAL JOINT, TUBE D'EAU	1				
29	6L5-44352-00	IMPELLER TURBINE	1				
30	93604-07M13	PIN, DOWEL CLAVETTE	1				
31	97095-06040	BOLT BOULON	4				
32	93604-18080	PIN, DOWEL CLAVETTE	2				
33	6L5-44328-00	PLATE PLAQUETTE	2				
34	6L5-44360-01	WATER TUBE ASSY TUYAU,EAU	1				S
	6L5-44360-11	WATER TUBE ASSY TUYAU,EAU	1				L
35	646-44365-00	.DAMPER, WATER SEAL .JOINT, TUBE D'EAU	1				
36	6L5-45511-00	SHAFT, DRIVE ARBRE, MOTEUR	1				S
	6L5-45511-10	SHAFT, DRIVE ARBRE, MOTEUR	1				L
37	90467-07M12	CLIP JONC	1				
38	6L5-45551-00	PINION PIGNON D'ATTAQUE	1				
39	99001-06600	CIRCLIP CIRCLIP	1				
40	6L5-45533-00	SHIM (T:2.0MM) CALE (T:2.0MM)	1				UR
	6L5-45533-10	SHIM (T:2.1MM) CALE (T:2.1MM)	1				UR
	6L5-45533-20	SHIM (T:2.2MM) CALE (T:2.2MM)	1				UR
	6L5-45533-30	SHIM (T:2.3MM) CALE (T:2.3MM)	1				UR
41	6L5-45560-00	GEAR PIGNON	1				
42	6L5-45611-00	SHAFT, PROPELLER ARBRE, HELICE	1				
43	90501-10064	SPRING, COMPRESSION RESSORT, COMPRESSION	1				
44	6L5-45635-00	PLUNGER, SHIFT POUSSOIR D'EMBAYAGE	1				
45	6L5-45631-00	CLUTCH, DOG CRABOT	1				
46	6L5-45987-01	SPACER ENTRETOISE	1				
47	90201-13198	WASHER, PLATE RONDELLE, PLATE	1				

FIG. 9 LOWER CASING. DRIVE

BOITIER D'HELICE, TRANSMISSION

REF. NO.	PART NO. NO. PIECES	DESCRIPTION DESCRIPTION	3A				REMARKS REMARQUES
48	6L5-45616-00	NUT, PROPELLER CONE, HELICE	1				
49	91490-25030	PIN, COTTER GOUPILLE	1				
50	90201-08M54	WASHER, PLATE RONDELLE, PLATE	1				
51	6L5-45943-00-EL	PROPELLER (3X7-1/4"X6"-BS) HELICE (3X7-1/4"X6"-BS)	1				UR
	6L5-45945-00-EL	PROPELLER (3X7-1/4"X7-1/4"-BS) HELICE (3X7-1/4"X7-1/4"-BS)	1				UR
	6L5-45947-00-EL	PROPELLER (3X7-1/4"X8-1/4"-BS) HELICE (3X7-1/4"X8-1/4"-BS)	1				UR
	6L5-45949-00-EL	PROPELLER (3X7-1/4"X5"-BS) HELICE (3X7-1/4"X5"-BS)	1				UR
	6L5-45952-00-EL	PROPELLER (3X7-1/4"X5-1/2"-BS) HELICE (3X7-1/4"X5-1/2"-BS)	1				UR
52	6L5-45211-00-4D	EXTENSION EXTENSION	1				L
53	6L5-45318-00	BUSHING, DRIVE SHAFT DOUILLE, ARBRE MOTEUR	1				L
54	93420-22M03	CIRCLIP CIRCLIP, TYPE S	1				L
55	90101-06M18	BOLT BOULON	3				L
56	92990-06600	WASHER, PLATE RONDELLE, PLATE	3				L
57	93604-12M07	PIN, DOWEL CLAVETTE	2				L

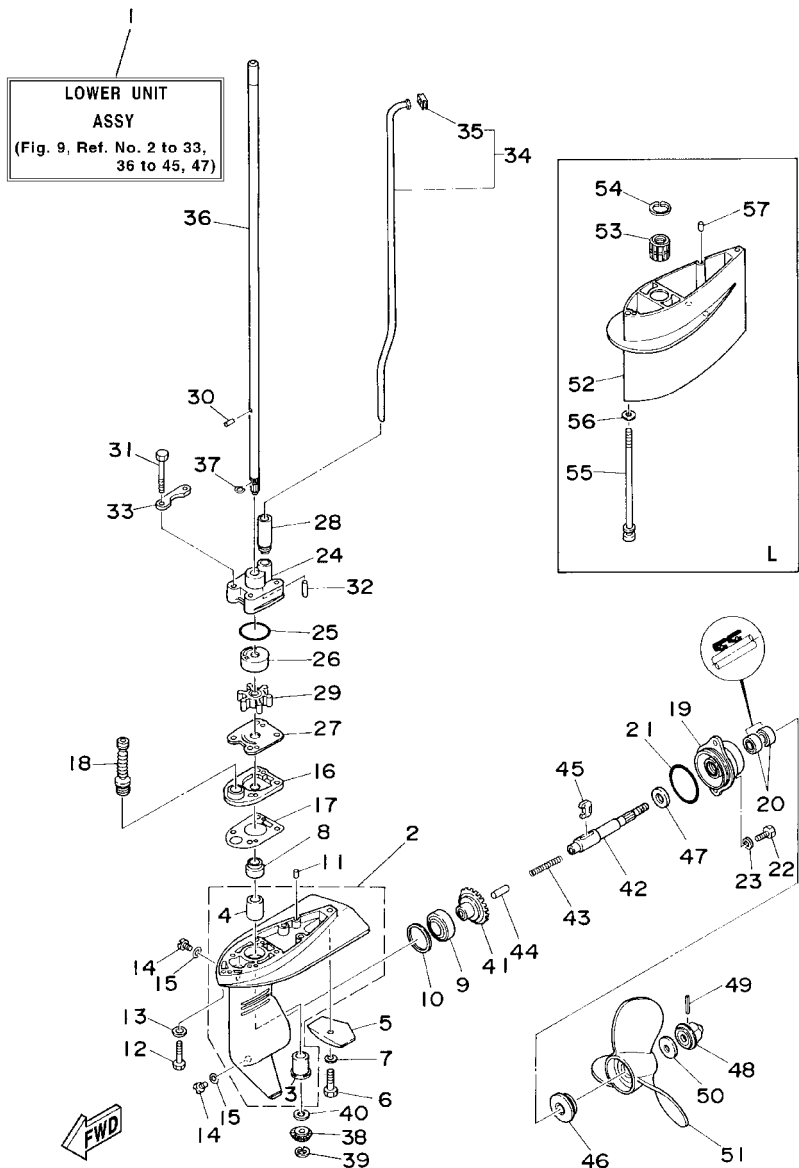

6L52300-4090

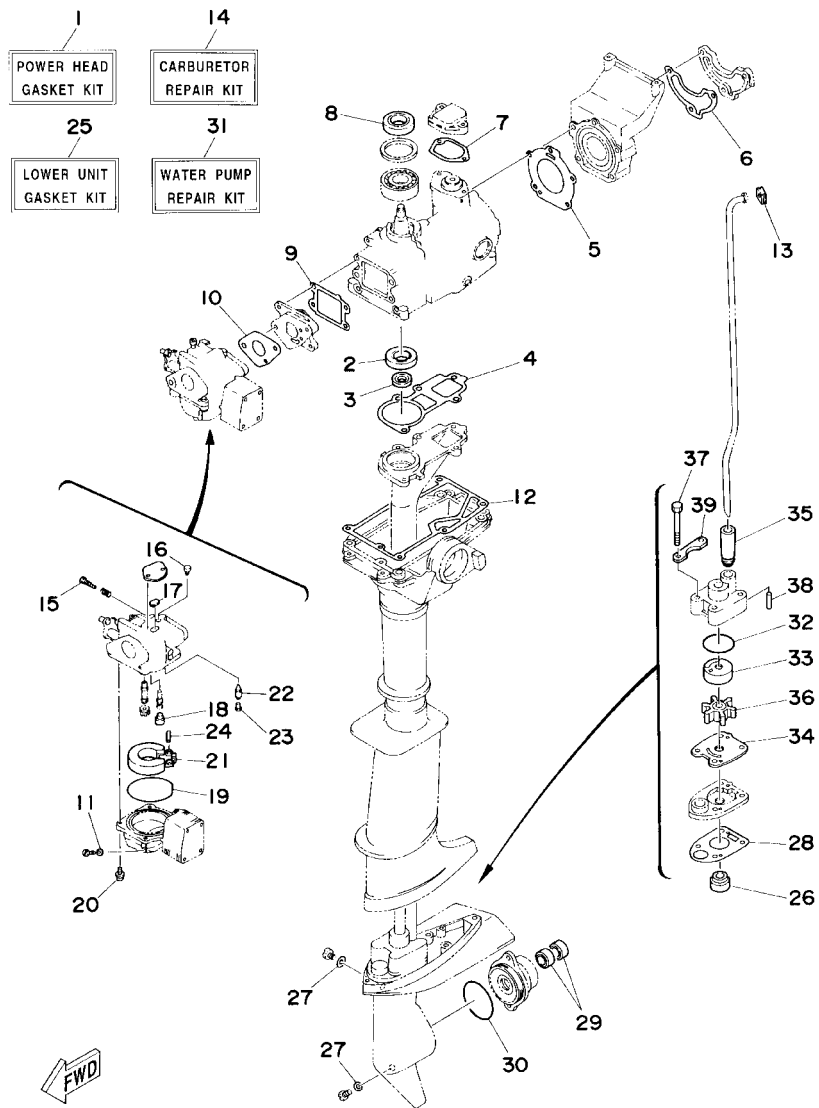

6L50010-4100

FIG. 10 REPAIR KIT

KITS DE REPARATION

REF. NO.	PART NO. NO. PIECES	DESCRIPTION DESCRIPTION	3A				REMARKS REMARQUES
1	6L5-W0001-A1	POWER HEAD GASKET KIT POCHETTE DE JOINTS	1				
2	93101-20M29	.OIL SEAL .JOINT SPY	1				
3	93101-09M42	.OIL SEAL .JOINT SPY	1				
4	6L5-15369-A0	.GASKET, OIL SEAL HOUSING .JOINT SPY DE LOGEMENT	1				
5	6L5-11181-A2	.GASKET, CYLINDER HEAD 1 .JOINT, DE CULASSE 1	1				
6	6L5-11193-A1	.GASKET, HEAD COVER 1 .JOINT, COUVERCLE DE CULASSE 1	1				
7	6L5-12414-A1	.GASKET, COVER .JOINT, COUVERCLE	1				
8	93102-20M06	.OIL SEAL .JOINT SPY	1				
9	6L5-13621-A2	.GASKET, VALVE SEAT .JOINT, SIEGE DE CLAPET	1				
10	6L5-14198-A1	.GASKET .JOINT	1				
11	6G1-14398-00	.WASHER .RONDELLE	1				
12	6L5-45113-A1	.GASKET, UPPER CASING .JOINT, TUBE D'ARBRE	1				
13	646-44365-00	.DAMPER, WATER SEAL .JOINT, TUBE D'EAU	1				
14	6G1-W0093-00	CARBURETOR REPAIR KIT KIT DE REPARATION CARBURATEUR	1				
15	679-14923-00	.SCREW, PILOT .VIS, RALENTI	1				
16	6G1-14966-00	.CAP .CAPUCHON	1				
17	6G1-14126-00	.GASKET .JOINT	1				
18	676-14966-00	.CAP .CAPUCHON	1				
19	6G1-14984-00	.O-RING .JOINT TORIQUE	1				
20	97980-04114	.SCREW, WITH WASHER .VIS, AVEC RONDELLE	4				
21	6G1-14985-00	.FLOAT .FLOTTEUR	1				
22	6G1-14546-00	.VALVE, NEEDLE .POINTEAU	1				
23	676-14186-00	.PIN, FLOAT .AXE, FLOTTEUR	1				
24	688-14548-00	.PIN, FLOAT ARM .AXE, BRAS DE FLOTTEUR	1				
25	6L5-W0001-21	LOWER UNIT GASKET KIT POCHETTE DE JOINTS EMBASE	1				
26	93103-09M41	.OIL SEAL .JOINT SPY	1				
27	90430-08020	.GASKET .JOINT	2				

**NUMERICAL INDEX
INDEX NUMERIQUE**

PART NO. NO. PIECES	REF. NO.	PART NO. NO. PIECES	REF. NO.	PART NO. NO. PIECES	REF. NO.	PART NO. NO. PIECES	REF. NO.	PART NO. NO. PIECES	REF. NO.	PART NO. NO. PIECES	REF. NO.
6L5-W0001-A1	10 - 1	6G1-14546-00	3 - 25	6G1-24432-00	3 - 34	6L5-42823-00	1 - 12	6L5-44511-00-4D	8 - 28	6L5-85540-M0	6 - 8
6L5-W0001-21	10 - 25		10 - 22	6G1-24452-00	3 - 33	6L5-43111-01-4D	8 - 10	6L5-44553-00-4D	8 - 27	6L5-85550-M0	5 - 1
6L5-W0004-02	3 - 2	688-14548-00	3 - 29	6G1-24471-00	3 - 35	6L5-43112-00-4D	8 - 11	6L5-45111-02-4D	8 - 1	6L5-85560-M1	5 - 2
6L5-W0070-13	1 - 2		10 - 24	6L5-24500-60	1 - 24	6A1-43113-01	8 - 21	6L5-45113-A1	2 - 42	6L5-85570-N0	6 - 5
6L5-W0078-00	10 - 31	679-14555-00	3 - 7	6L5-24591-00	1 - 15	620-43114-00	8 - 12		10 - 12	6L5-85592-M0	5 - 5
6L5-W0090-01-1S	2 - 1	679-14923-00	3 - 6	6L5-24610-20	1 - 19	6E0-43116-01	8 - 13	6L5-45115-A0	8 - 7	6L5-85595-M0	5 - 4
6G1-W0093-00	10 - 14		10 - 15	6L5-24641-00	1 - 23	6E0-43118-01	8 - 14	647-45151-01	8 - 9	90101-06M18	9 - 6
656-W2810-02	1 - 34	676-14943-14	3 - 20	6L5-26301-01	7 - 23	6G1-43136-00	8 - 17	6L5-45152-00	8 - 6		9 - 55
6L5-11111-00-1S	2 - 16	6L5-14947-01	3 - 19	6A1-28176-00	1 - 33	6L5-43160-00	8 - 39	6L5-45211-00-4D	9 - 52	90101-06335	8 - 23
6L5-11181-A2	2 - 17	6L5-14948-03	3 - 11	6A1-28199-7L-A0	1 - 35	6L5-43181-00	8 - 34	6L5-45251-03	9 - 5	90101-08M10	8 - 16
	10 - 5	6G1-14966-00	3 - 8	6A1-28199-7L-B0	1 - 35	620-43189-00	8 - 34	6L5-45300-01-4D	9 - 1	90105-06M16	2 - 8
6L5-11191-00-1S	2 - 19		10 - 16	6A1-28199-8M-A0	1 - 36	6L5-43311-01-4D	8 - 26	6L5-45300-11-4D	9 - 1	90105-06M40	2 - 9
6L5-11193-A1	2 - 20	676-14966-00	3 - 12	6A1-28199-8M-B0	1 - 36	6E0-43313-00-94	8 - 31	6L5-45311-00-4D	9 - 2	90119-06MA2	2 - 21
	10 - 6		10 - 18	6L5-41252-00	3 - 45	6L5-43318-11	8 - 55	6L5-45315-A0	9 - 17		2 - 26
6E5-11372-01	2 - 4	6G1-14980-01	3 - 18	6L5-41271-20	3 - 44	6L5-43614-00	8 - 40		10 - 28	90119-06M65	1 - 22
6L5-11400-00	2 - 27	6G1-14984-00	3 - 17	689-41273-00	3 - 47	6L5-43659-00	8 - 43	6L5-45316-09	9 - 4	90119-06027	2 - 22
6L5-11412-00	2 - 28		10 - 19	6J8-41274-00	3 - 48	6L5-44111-00	7 - 24	6L5-45317-09	9 - 3	90119-06047	2 - 18
6L5-11422-00	2 - 29	6G1-14985-00	3 - 24	6G1-42111-11-4D	7 - 1	6L5-44121-00	7 - 30	6L5-45318-00	9 - 53	90149-05M08	8 - 8
6L5-11610-00	2 - 38		10 - 21	664-42119-00	7 - 8	6L5-44143-00	7 - 33	6L5-45321-00-5B	9 - 16	90149-05M13	7 - 14
6L5-11610-10	2 - 38	6G1-14992-00	3 - 23	6L5-42121-00	8 - 18	6L5-44144-00	7 - 39	6L5-45361-00-4D	9 - 19	90159-04035	5 - 11
6L5-11610-20	2 - 38	6L5-15100-00-1S	2 - 2	6L5-42125-00	7 - 20	6L5-44144-10	7 - 39	6L5-45511-00	9 - 36	90159-04036	5 - 10
6L5-11631-00-96	2 - 37	6L5-15369-A0	2 - 13	6G1-42126-00	7 - 21	6E0-44145-00	7 - 36	6L5-45511-10	9 - 36	90159-05037	5 - 9
6L5-11633-00	2 - 40		10 - 4	6G1-42131-01	7 - 6	6E0-44146-00	7 - 37	6L5-45533-00	9 - 40	90159-05038	5 - 8
6L5-11635-00	2 - 37	6L5-15396-00-94	2 - 10	6L5-42137-20	7 - 10	6L2-44147-00	9 - 18	6L5-45533-10	9 - 40	90159-06M10	1 - 25
6L5-11636-00	2 - 37	6A1-15705-00	4 - 8	6G1-42138-01	7 - 17	6L5-44191-00	1 - 14	6L5-45533-20	9 - 40		8 - 56
6L5-11651-00	2 - 30	6L5-15710-00	4 - 1	6E0-42159-02	7 - 18	6L5-44196-20	1 - 26	6L5-45533-30	9 - 40	90161-04M02	7 - 43
6L5-11681-00	2 - 31	6L5-15711-00	4 - 2	6G1-42177-00	7 - 9		7 - 26	6L5-45551-00	9 - 38	90167-03M02	1 - 13
6E5-12411-01	2 - 23	6L5-15713-00	4 - 6	6E0-42528-03	8 - 49		8 - 35	6L5-45560-00	9 - 41	90170-10113	5 - 18
6L5-12413-00-1S	2 - 24	6L5-15714-00	4 - 4	6L5-42529-01	8 - 50		8 - 53	6L5-45567-00	9 - 10	90185-08057	8 - 20
6L5-12414-A1	2 - 25	6L5-15716-00	4 - 7	6L5-42537-00	8 - 45	6L5-44197-20	1 - 27	6L5-45611-00	9 - 42	90201-08M54	9 - 50
	10 - 7	6L5-15741-00	4 - 5	6L5-42538-00	8 - 46		7 - 27	6L5-45616-00	9 - 48	90201-10126	5 - 19
6L5-13610-02	3 - 1	6L5-15755-00	4 - 18	6L5-42539-00	8 - 47		8 - 36	6L5-45631-00	9 - 45	90201-13198	9 - 47
6L5-13621-A2	3 - 3	6L5-15758-00-98	4 - 14	624-42542-00	1 - 21		8 - 54	6L5-45635-00	9 - 44	90201-32M00	2 - 35
	10 - 9	6L5-15761-00	4 - 16	6L5-42549-00	8 - 48	6L5-44311-00	9 - 24	6L5-45943-00-EL	9 - 51	90201-32M01	2 - 36
6G1-14126-00	3 - 10	6A1-15767-00	4 - 10	6L5-42561-00	8 - 51	6L5-44322-00	9 - 26	6L5-45945-00-EL	9 - 51	90202-36M55	7 - 3
	10 - 17	6L5-15771-01-94	5 - 12	6L5-42610-54-4D	1 - 1		10 - 33	6L5-45947-00-EL	9 - 51	90206-36M21	7 - 2
663-14159-00	3 - 27	6L5-15779-20	4 - 19	6L5-42647-00	1 - 11	6L5-44323-00	9 - 27	6L5-45949-00-EL	9 - 51	90209-08M17	7 - 15
676-14186-00	3 - 26	6L5-15789-00	4 - 20	6L5-42662-00	1 - 16		10 - 34	6L5-45952-00-EL	9 - 51	90243-04M01	8 - 15
	10 - 23	6L5-24111-02	1 - 18	6L5-42663-00	1 - 17	6L5-44328-00	9 - 33	6L5-45987-01	9 - 46	90266-04M05	8 - 52
6L5-14198-A1	3 - 40	6A1-2415A-41	7 - 46	6L5-42677-10	4 - 17		10 - 39	6E0-81328-70	5 - 7	90269-02M09	7 - 11
	10 - 10	6A1-2415A-51	7 - 47	6L5-42678-51	1 - 3	6L5-44352-00	9 - 29	6E0-81336-70	5 - 6	90280-04M06	5 - 17
6L5-14301-03	3 - 5	6L5-24251-00	1 - 28	6L5-42711-11	1 - 4		10 - 36	6L5-82316-00	6 - 2	90340-08002	9 - 14
6G1-14398-00	3 - 22	6L5-24311-00	1 - 29	6L5-42712-12	1 - 5	6L5-44360-01	9 - 34	6A0-82317-00	1 - 20	90386-08032	7 - 16
	10 - 11	6L5-24312-00	1 - 31	6L5-42731-00-4D	7 - 41	6L5-44360-11	9 - 34	6G1-82370-21	6 - 1	90386-33M96	7 - 5
6L5-14440-00	3 - 41	6G1-24411-00	3 - 37	6L5-42735-20	7 - 42	646-44365-00	9 - 35	6L5-82550-00	6 - 12	90386-34M97	7 - 4
624-14485-00	2 - 3	6G1-24412-01	3 - 36	6L5-42774-00	1 - 6		10 - 13	6A1-83625-41	4 - 22	90387-06M11	8 - 22
63V-14523-00	3 - 16	6L5-24421-00	3 - 39	6L5-42775-00	1 - 7	6E0-44366-00	9 - 28	6A1-83625-51	4 - 23	90387-06M70	4 - 3
6G1-14527-00	3 - 9	6G1-24431-01	3 - 38	6H8-42791-10	4 - 21		10 - 35	6E0-85520-70	5 - 3	90430-08020	9 - 15

NUMERICAL INDEX
INDEX NUMERIQUE

PART NO. NO. PIECES	REF. NO.	PART NO. NO. PIECES	REF. NO.	PART NO. NO. PIECES	REF. NO.	PART NO. NO. PIECES	REF. NO.	PART NO. NO. PIECES	REF. NO.	PART NO. NO. PIECES	REF. NO.
90430-08020	10 - 27	93103-09M41	9 - 8	97780-40520	7 - 31						
90445-07M29	2 - 5		10 - 26	97780-40716	3 - 42						
90446-10M01	5 - 13	93210-12327	7 - 25	97803-05008	5 - 14						
90465-10M34	5 - 15	93210-33M85	9 - 25	97880-04010	3 - 13						
90465-13M11	1 - 32		10 - 32	97880-05010	1 - 8						
90465-18147	6 - 11	93210-48214	9 - 21	97880-06016	6 - 6						
90467-06016	2 - 6		10 - 30	97885-05012	7 - 19						
90467-07M12	9 - 37	93306-204U0	2 - 33	97980-04114	3 - 21						
90467-08004	1 - 30	93310-112U0	2 - 39		10 - 20						
90501-10064	9 - 43	93310-416N7	2 - 32	97980-04125	3 - 32						
90501-10326	3 - 15	93316-003U0	9 - 9	98580-03006	3 - 30						
90501-12274	7 - 29	93420-22M03	9 - 54	98580-04008	3 - 28						
90501-23215	7 - 12	93450-13022	2 - 41	99001-06600	9 - 39						
90508-08M26	8 - 41	93505-16024	7 - 28	99080-03600	7 - 22						
90508-08M27	8 - 42	93604-07M13	9 - 30	99080-05600	8 - 44						
90508-16M30	8 - 19	93604-12M07	8 - 2								
90508-16020	8 - 37		9 - 11								
90508-16021	8 - 38		9 - 57								
91490-16010	7 - 35	93604-18080	9 - 32								
91490-25030	9 - 49		10 - 38								
91609-25014	7 - 40	93606-12019	2 - 7								
91690-40048	3 - 46	93700-06M03	8 - 5								
92903-10600	7 - 13	94702-00274	2 - 43								
92990-04100	3 - 14	95380-03600	3 - 31								
92990-04600	7 - 32	95380-06600	8 - 25								
92990-05600	7 - 34	95895-06016	3 - 4								
92990-06300	9 - 7		4 - 15								
92990-06600	6 - 7		5 - 16								
	6 - 14	95895-06020	4 - 12								
	8 - 24		7 - 38								
	9 - 56		8 - 33								
92995-06600	1 - 10	95895-06030	9 - 6								
	2 - 15	95895-06035	4 - 13								
	6 - 4	95895-06095	3 - 43								
	6 - 10	97090-06012	6 - 13								
	7 - 45	97095-06016	1 - 9								
	8 - 4		6 - 3								
	8 - 30		6 - 9								
	9 - 13		9 - 22								
	9 - 23	97095-06020	2 - 14								
93101-09M42	2 - 12		7 - 7								
	10 - 3		7 - 44								
93101-13M12	9 - 20	97095-06030	8 - 3								
	10 - 29		9 - 12								
93101-20M29	2 - 11	97095-06035	8 - 29								
	10 - 2	97095-06040	9 - 31								
93102-20M06	2 - 34		10 - 37								
	10 - 8	97313-06012	4 - 9								

3AMH
PARTS CATALOGUE
©2002 by Yamaha Motor Co., Ltd.
1st Edition, Jul. 2002
All rights reserved.
Any reprinting or unauthorized use
without the written permission of
Yamaha Motor Co., Ltd.
is expressly prohibited.

3AMH
CATALOGUE DE PIECES DETACHEES
©2002 Yamaha Motor Co., Ltd.
1ère Edition, Juil. 2002
Tous droits réservés.
Toute réimpression ou utilisation
sans la permission écrite de la
Yamaha Motor Co., Ltd.
est formellement interdite.